

Goodrive10 inverters



Brief introduction of Goodrive10 inverters

Goodrive10 Series mini-economy inverters are designed for the small-power OEM application market. With The function of vectorization V/f control and PID function, multi- step speed, DC braking and Modbus communication and so on, the inverter has more advantages but occupied less installation space.

Advantages

1. V/f control

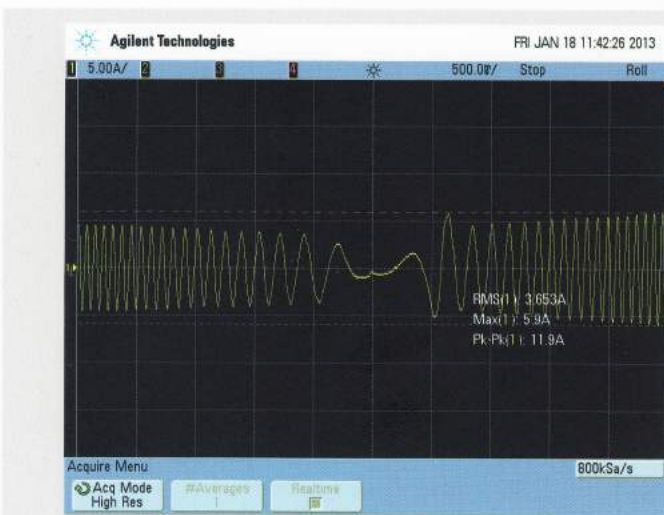

FWD/REV current waveform with full load at 50Hz

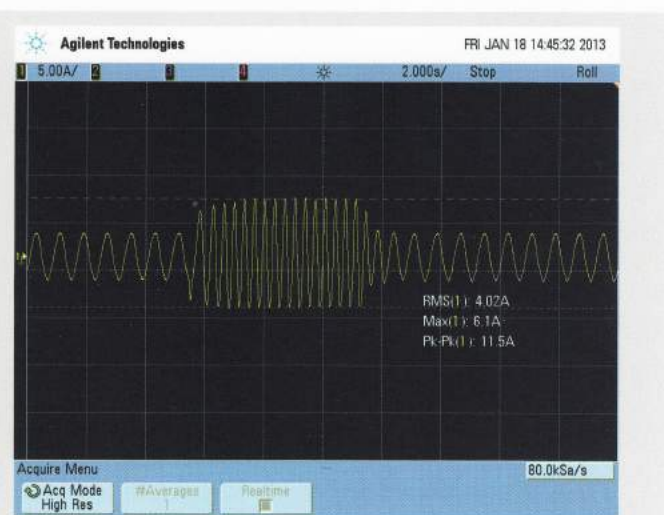

Current waveform in sudden acceleration/deceleration at 0.5Hz

2. Natural cooling(for the applications with cotton and dust)



Remarks:

1. Natural cooling: single phase or three phase 220V 0.2-0.75kW.
2. Air forced cooling: single phase or three phase 220V 1.5-2.2kW, three phase 380V 0.75-2.2kW.

3. Mini structure, less installation space)



GD100-2R2-4

GD10-2R2-4

4. Standard potentiometer and external LED keypad

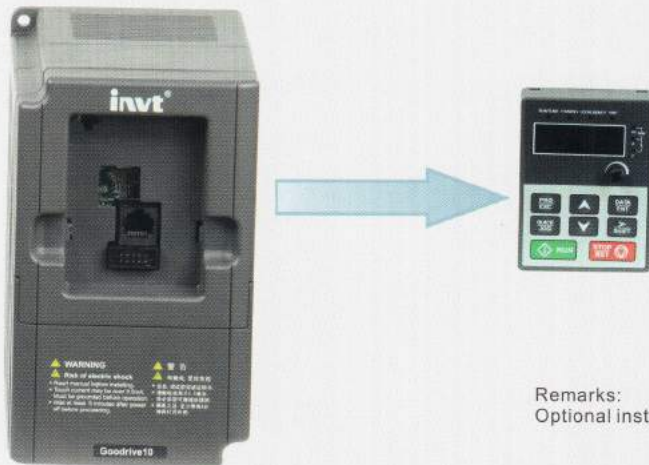

Remarks:
Optional installation bracket is needed when install external keypad.

5. Follow IEC GB standards, and meet the testing requirements of CE certification



6. Various function setting

- (1) Standard Modbus communication
- (2) Built-in PID
- (3) 16 steps multi-step speed control
- (4) Flexible V/f curve setting
- (5) Multi-function I/O terminal (the delay time can be set)
- (6) Fault protection at overcurrent, overvoltage, undervoltage, overtemperature and overload with detailed fault information
- (7) DC braking, flux braking and resistor dynamic braking
- (8) Overcurrent and overvoltage stall, stronger load adaptability

Technical specifications

Function	Specification
Input voltage (V)	Single phase 220(-15%)~240(+10%) Three phase 220(-15%)~240(+10%) Three phase 380(-15%)~440(+10%)
Input frequency (Hz)	50Hz or 60Hz Allowed range: 47~63Hz
Output voltage (V)	Equal to input voltage with the deviation of less than 5%
Output frequency (Hz)	50Hz/60Hz, Fluctuation range: $\pm 5\%$
Control mode	V/f
Maximum output frequency	400Hz
Adjustable-speed ratio	1:100
Overload capability	150% of rated current: 1 minute, 180% of rated current: 10 seconds, 200% of rated current: 1 second
Terminal analog input resolution	$\leq 20\text{mV}$
Terminal switch input resolution	$\leq 2\text{ms}$
Analog input/output	1 input 0~10V/0~20mA; 1 output 0~10V/0~20mA
Digital input/output	5 common input, 1 Y output (commonly used with digital output) and 1 rogrammable relay output
Communication	485 communication
Mountable method	Wall mountable
Temperature of the running environment	-10~50°C, derate above 40°C
Cooling	Single/three-phase 220V 0.2-0.75kW natural cooling
	Single/three-phase 220V 1.5-2.2kW, three-phase 380V 0.75-2.2kW
Fault protections	Overcurrent, overvoltage, undervoltage, overtemperature, overload and other protections
Braking unit	Only standard for GD10-B

Applications:

Packaging machinery, food machinery, textile machinery, centrifuge, engraving machine, and cutting machine, etc.

Standard wiring

Wiring diagram of main circuit

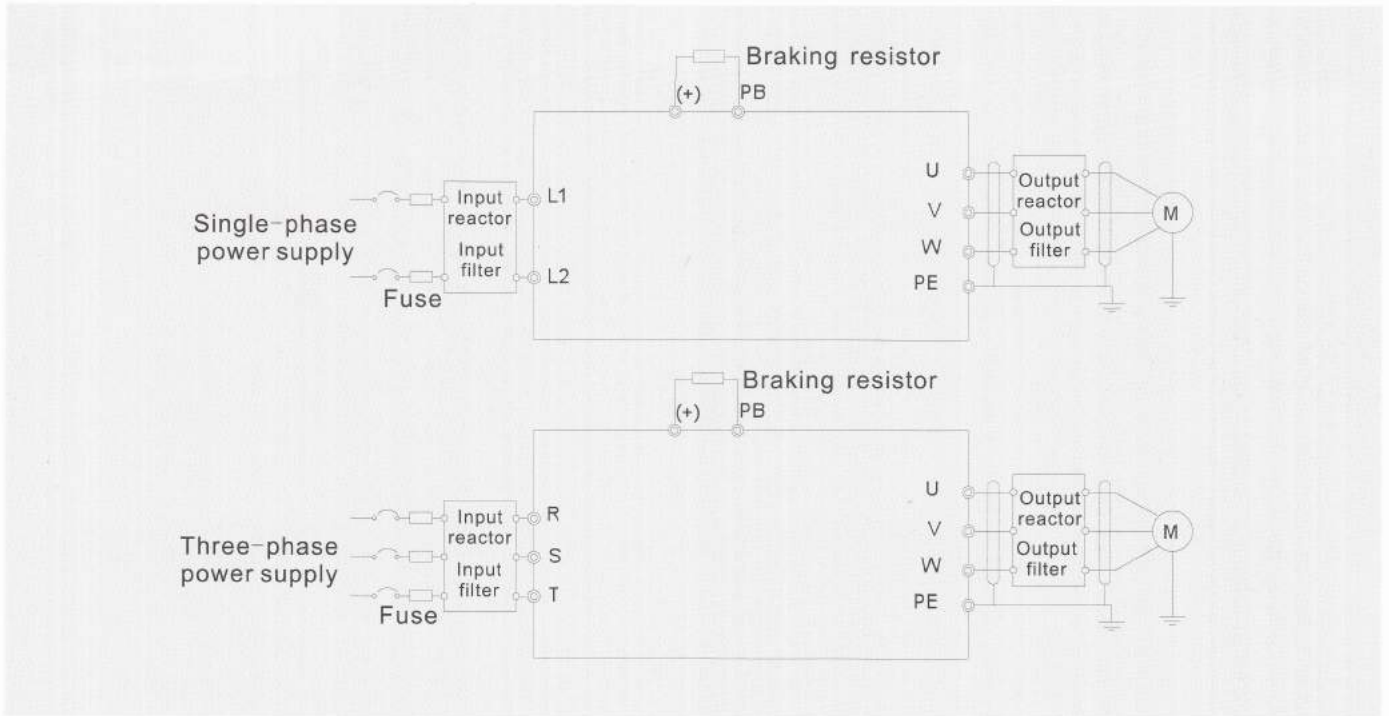

Wiring diagram of control circuit

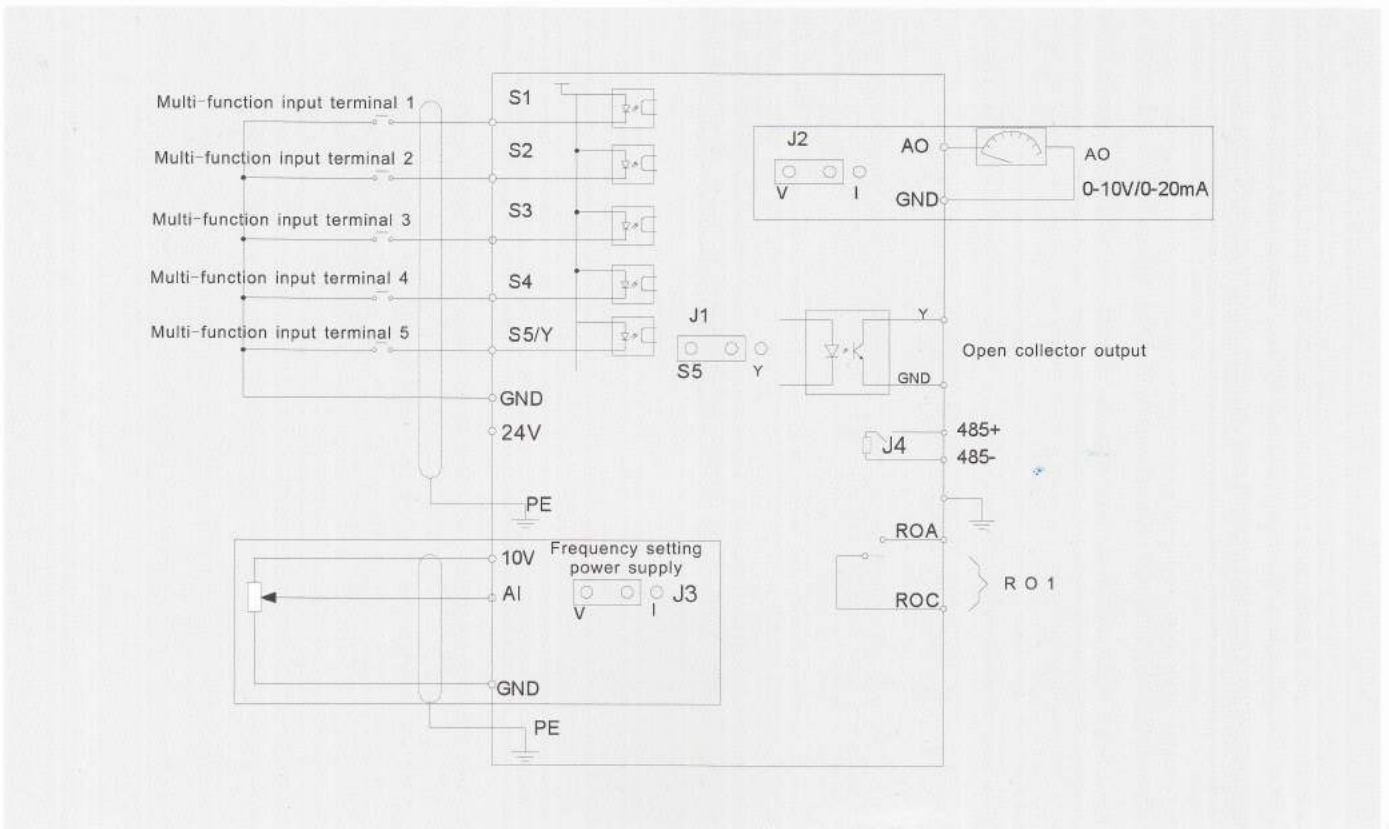

Standard wiring

Wiring diagram of main circuit

GD10 - 2R2G - 4 - B

① ② ③ ④

Field identification	Sign	Detailed description of the sign	Detailed content
Abbreviation	①	Product abbreviation	Goodrive10 is shorted for GD10
Rated power	②	Power range + Load type	2R2-2.2kW GC onstant torque load
Voltage degree	③	Voltage degree	4:three-phase 380V 2: three-phase 220V S2: single-phase 220V
Lot No.	④	Lot No.	Default: No braking unit B: Built-in braking unit

Rated specifications

Model	Output power(kW)	Input current(A)	Output current (A)	
Single-phase 230V	GD10-0R2G-S2-B	0.2	4.9	1.6
	GD10-0R4G-S2-B	0.4	6.5	2.5
	GD10-0R7G-S2-B	0.75	9.3	4.2
	GD10-1R5G-S2-B	1.5	15.7	7.5
	GD10-2R2G-S2-B	2.2	24	10
Three-phase 230V	GD10-0R2G-2-B	0.2	1.9	1.6
	GD10-0R4G-2-B	0.4	2.7	2.5
	GD10-0R7G-2-B	0.75	4.9	4.2
	GD10-1R5G-2-B	1.5	9	7.5
	GD10-2R2G-2-B	2.2	15	10
Three-phase 400V	GD10-0R7G-4-B	0.75	3.2	2.5
	GD10-1R5G-4-B	1.5	4.3	4.2
	GD10-2R2G-4-B	2.2	7.1	5.5

Installation dimension

1. Inverter dimensions

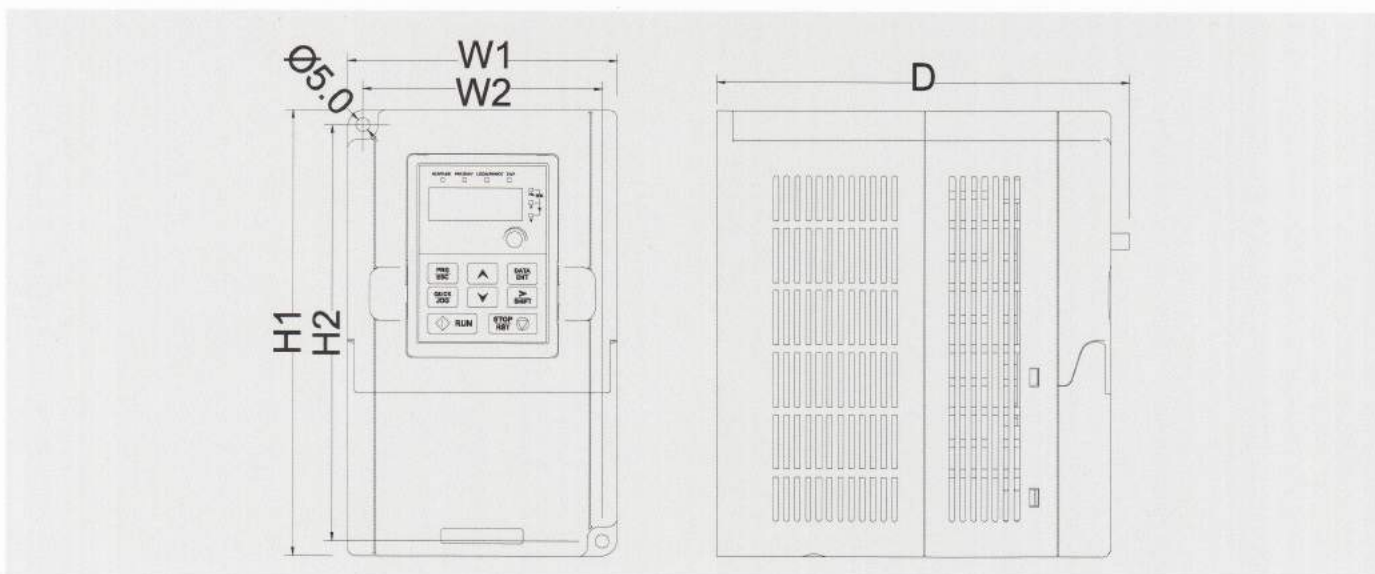

Model		W1 (mm)	W2 (mm)	H1 (mm)	H2 (mm)	D (mm)
Single-phase 220V	GD10-0R2G-S2-B	85	75	140	132	134.2
	GD10-0R4G-S2-B	85	75	140	132	153.2
	GD10-0R7G-S2-B	100	89	165	154	153.2
	GD10-1R5G-S2-B	100	89	165	154	153.2
	GD10-2R2G-S2-B	100	89	165	154	153.2
Three-phase 220V	GD10-0R2G-2-B	85	75	140	132	134.2
	GD10-0R4G-2-B	85	75	140	132	153.2
	GD10-0R7G-2-B	100	89	165	154	153.2
	GD10-1R5G-2-B	100	89	165	154	153.2
	GD10-2R2G-2-B	100	89	165	154	153.2
Three-phase 380V	GD10-0R7G-4-B	100	89	165	154	153.2

2. External keypad installation

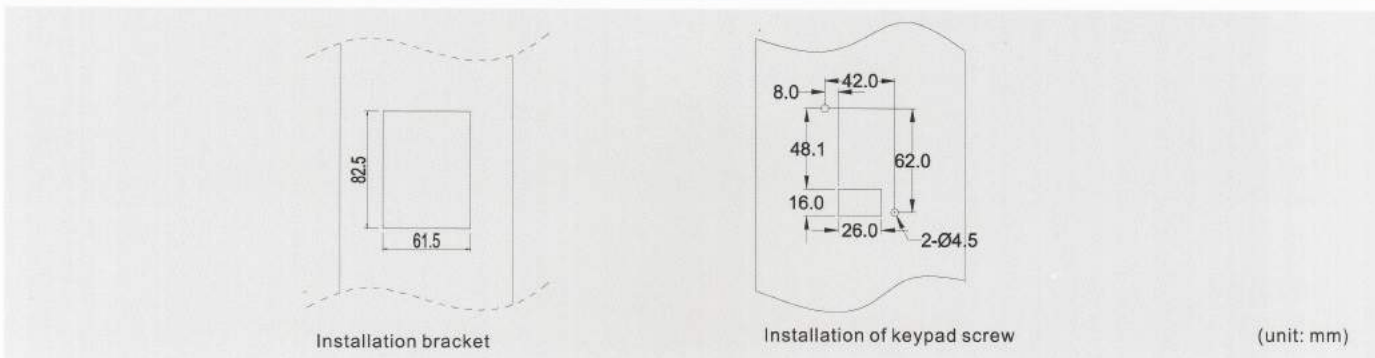

(unit: mm)

Innovation, Value, Teamwork

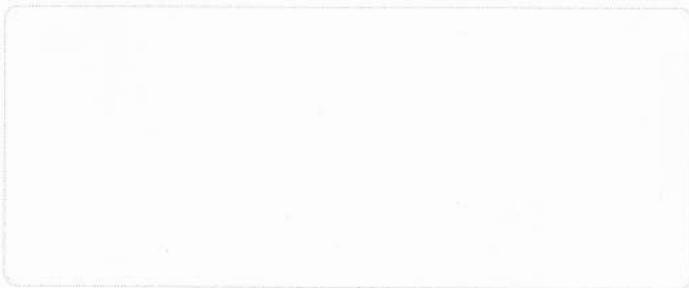

Service line:86-755-86312859 E-mail:overseas@invt.com.cn

SHENZHEN INVT ELECTRIC CO., LTD.

No. 4 Building, Gaofa Scientific Industrial Park, Longjing, Nanshan District, Shenzhen, China

- | | | | | |
|---------------------|--------------------------|---------------------------------------|------------------|-----------------------------------|
| Electric Drive: | ■ Frequency Inverter | ■ Intelligent Elevator Control System | ■ Traction Drive | |
| Industrial control: | ■ Servo & Motion Control | ■ Motor & Electric Spindle | ■ PLC | ■ HMI |
| New energy: | ■ SVG | ■ Solar Inverter | ■ UPS | ■ Online Energy Management System |

INVT Copyright.
Information may be subject to change without notice during product improving.

201212 (V1.1)